



COMBINATION OF
EXTERNAL WEATHER
LOUVRE AND NON-
RETURN DAMPER,
VARIANT WG-AL-KUL-1

WG-KUL

COMBINATION WITH A NON-RETURN DAMPER

Combinations of external weather louvres and non-return dampers as a protection against the direct ingress of rain, leaves and birds, and to prevent air from flowing against the intended airflow direction.

- Maximum width of 2000 mm, maximum height of 1665 mm
- Low differential pressure due to aerofoil blades
- Low air-regenerated noise
- All aerodynamic data is measured in aerodynamics and acoustics laboratories
- Maximum differential pressure: 100 Pa
- Available in standard sizes and many intermediate sizes
- Pre-assembled combination, hence fast and easy to install

Optional equipment and accessories

- Installation subframe
- Insect screen
- Powder-coated or anodised surface

Application



Application

- Combinations of Type WG external weather louvres and Type KUL non-return dampers for protecting fresh air and exhaust air openings in air conditioning systems
- Protection against the direct ingress of rain as well as against leaves and birds
- Recommended face velocity for fresh air openings: 2 – 2.5 m/s max.
- Prevention of unwanted airflows against the intended airflow direction when the system is not in operation
- Blades close automatically when the system is shut down

Special characteristics

- Any intermediate sizes within the standard size range are available
- Low installation effort on site since external weather louvre and non-return damper are factory combined and assembled
- Operating temperature 20 – 80 °C
- For very large sizes, several combinations can be arranged side by side or on top of each other
- Maximum pressure of 100 Pa
- Low differential pressure due to aerofoil blades
- Non-return dampers are opened and closed by the airflow; no actuator is required

Nominal sizes

- B: 200 – 1600 mm, in increments of 1 mm
- H: 180, 345, 510, 675, 840, 1005, 1170, 1335, 1500, 1665 mm (intermediate sizes 183 – 1664 in increments of 1 mm)
- Any combination of B × H

Description



Variants

- WG-KUL: External weather louvre made of galvanised sheet steel, with non-return damper

- WG-AL-KUL: External weather louvre made of aluminium, with non-return damper
- 1: Fresh air opening
- 2: Exhaust air opening

Parts and characteristics

- Border
- Regular blades and bottom blade
- Wire mesh
- Optional insect screen
- Visible mullion or stabilising mullion at the rear, from B = 1385 mm
- Casing of non-return damper
- Blades with low-friction bearings
- Blade restrictors
- Blade tip seals
- Bottom travel stop (angle section)
- Visible mullion at the rear from B = 1000 mm

Accessories

- Installation subframe: Installation subframe for the fast and simple installation of external weather louvres

Construction features

External weather louvre

- Free area of approx. 60 %, with insect screen approx. 45 %
- Wire mesh at the rear, mesh aperture 20 × 20 × 1.8 mm
- Optional insect screen at the rear, mesh aperture 1.25 × 1.25 × 0.4 mm
- Border fixing holes

Non-return damper

- Casing, material thickness 1.25 mm
- Blades, material thickness 1 mm
- Flanges on both sides, suitable for duct connection, with corner holes
- Additional side bar with fixing holes to accommodate the blade shafts and integral blade restrictors (pins)
- Blade restrictors prevent the blades from opening beyond a certain angle

Materials and surfaces

- Border, mullion and blades made of formed galvanised sheet steel or aluminium
- Wire mesh made of galvanised steel or stainless steel
- Casing and travel stop of the non-return damper made of galvanised sheet steel
- Blades made of formed aluminium
- Mullion (from B = 1000 mm) made of galvanised sheet steel
- Blade shafts made of brass
- Side bar made of PVC plastic
- Blade tip seals made of foamed polyester
- Blade restrictors made of plastic
- P1: Powder-coated, RAL CLASSIC colour
- PS: Powder-coated, NCS or DB colour

Maintenance

- Maintenance-free as construction and materials are not subject to wear
- Contamination should be removed as it may lead to corrosion and to increased closed blade air leakage

TECHNICAL INFORMATION

Function, Technical data, Quick sizing, Specification text, Order code, related Products



Functional description

External weather louvres are externally mounted air transfer devices for the fresh air and exhaust air of air conditioning systems. They are installed in external walls and façades. Their narrowly arranged blades give good protection against the direct ingress of rain as well as against leaves and birds.

Under certain unfavourable conditions, such as heavy rain, and depending on the airflow velocity it might happen that slight quantities of water enter together with the air.

This is why the airflow velocity in fresh air openings should not exceed 2 – 2.5 m/s.

Non-return dampers close automatically.

When the system is in operation, the blades open when air flows.

When the system is shut down, the blades close due to their weight. They safely prevent air from flowing against the intended airflow direction.

Schematic illustration of WG-KUL

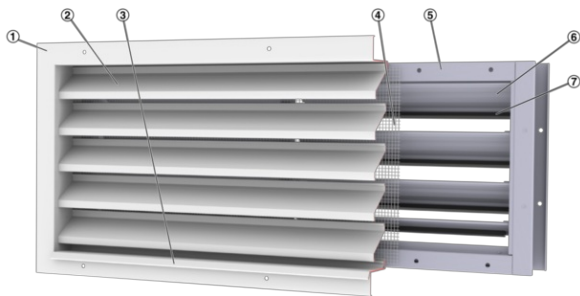

- ① WG border
- ② WG regular blades
- ③ WG bottom blade
- ④ WG wire mesh
- ⑤ KUL casing
- ⑥ KUL blade
- ⑦ KUL blade tip seal

Nominal sizes	200 × 180 to 1600 × 1665 mm
Free area	Approx. 60 %, with insect screen approx. 45 %
Total differential pressure – exhaust air	55 Pa at 2.5 m/s
Total differential pressure – fresh air	60 Pa at 2.5 m/s
Operating temperature	-20 to 80 °C
Maximum pressure	100 Pa

Combinations of an external weather louvre and a non-return damper.

Rectangular external weather louvre as a protection of air conditioning systems against the direct ingress of rain, leaves and birds into fresh air and exhaust air openings.

Rectangular non-return damper to prevent air from flowing against the intended airflow direction.

Ready-to-install component which consists of a border, aerofoil rain defence blades, and a wire mesh at the rear.

Non-return damper which consists of a casing, blades with low-friction bearings, and travel stop and sealing parts.

Special characteristics

- Any intermediate sizes within the standard size range are available
- Low installation effort on site since external weather louvre and non-return damper are factory combined and assembled
- Operating temperature 20 – 80 °C
- For very large sizes, several combinations can be arranged side by side or on top of each other
- Maximum pressure of 100 Pa
- Low differential pressure due to aerofoil blades
- Non-return dampers are opened and closed by the airflow; no actuator is required

Materials and surfaces

- Border, mullion and blades made of formed galvanised sheet steel or aluminium
- Wire mesh made of galvanised steel or stainless steel
- Casing and travel stop of the non-return damper made of galvanised sheet steel
- Blades made of formed aluminium
- Mullion (from B = 1000 mm) made of galvanised sheet steel
- Blade shafts made of brass
- Side bar made of PVC plastic
- Blade tip seals made of foamed polyester
- Blade restrictors made of plastic
- P1: Powder-coated, RAL CLASSIC colour
- PS: Powder-coated, NCS or DB colour

Technical data

- Nominal sizes: 200 × 180 to 1600 × 1665 mm
- Free area: approx. 60 %, with insect screen approx. 45 %
- Total differential pressure – exhaust air: 55 Pa at 2.5 m/s
- Total differential pressure – fresh air: 60 Pa at 2.5 m/s
- Operating temperature: –20 – 80 °C
- Maximum pressure: 100 Pa

Sizing data

- V _____ [m³/h]
- Δp_t _____ [Pa]

Air-regenerated noise

- L_{WA} _____ [dB(A)]

This specification text describes the general properties of the product. Texts for variants can be generated with our Easy Product Finder design programme.

Notes on the order code

© The nominal size equals the dimensions of the duct connected to the non-return damper. Depending on the size of the installation opening, an installation subframe may have to be used.

- Installation opening without installation subframe: B + 95 mm, H + 95 mm
- Installation opening with installation subframe: B + 115 mm, H + 115 mm

Order example: WG-KUL-1/1600x600/ER

Material – WG	Galvanised steel
Construction – WG	Wire mesh
Direction of airflow	Fresh air opening
Nominal size	1600x600 mm
Installation subframe – WG	With
Surface – WG	Standard construction

WG – AL – 2 – ... – KUL – 1 / 600x510 / ER / P1 – RAL ...



1 Type

WG-KUL Combination of external weather louvre and non-return damper

2 Material – WG

No entry: galvanised steel
AL Aluminium

3 Construction – WG

No entry: wire mesh
1 Insect screen, galvanised steel
2 Wire mesh, stainless steel (only WG-AL)
3 Insect screen and wire mesh made of stainless steel (only WG-AL)

4 WG border

No entry: With fixing holes
U Without fixing holes

5 Airflow direction

1 Fresh air opening
2 Exhaust air opening

6 Nominal size [mm]

B × H

7 Installation subframe – WG

No entry: None
ER With (not for construction without fixing holes)

8 Surface – WG

No entry: standard construction
P1 Powder-coated, RAL Classic colour
PS Powder-coated, DB colour
Only for WG-AL
S2 Anodised to EURAS standard, E6-C... (31 to 35)
S3 Anodised to EURAS standard, E6-C-0

Gloss level
RAL 9010 50 %
RAL 9006 30 %
All other RAL colours 70 %

Accessories

[Type Installation subframe](#)



WG-KUL

Variants

- External weather louvre made of galvanised sheet steel, with non-return damper
- 1: Fresh air opening
- 2: Exhaust air opening

Nominal sizes

- B: 200 – 1600 mm, in increments of 1 mm
- H: 180, 345, 510, 675, 840, 1005, 1170, 1335, 1500, 1665 mm (intermediate sizes 183 – 1664 in increments of 1 mm)
- Any combination of B × H

Parts and characteristics

- Border
- Regular blades and bottom blade
- Wire mesh
- Optional insect screen
- Visible mullion or stabilising mullion at the rear, from B = 1385 mm
- Casing of non-return damper
- Blades with low-friction bearings
- Blade restrictors
- Blade tip seals
- Bottom travel stop (angle section)
- Visible mullion at the rear from B = 1000 mm

Construction features

External weather louvre

- Free area of approx. 60 %, with insect screen approx. 45 %
- Wire mesh at the rear, mesh aperture 20 × 20 × 1.8 mm
- Optional insect screen at the rear, mesh aperture 1.25 × 1.25 × 0.4 mm
- Border fixing holes

Non-return damper

- Casing, material thickness 1.25 mm
- Blades, material thickness 1 mm
- Flanges on both sides, suitable for duct connection, with corner holes
- Additional side bar with fixing holes to accommodate the blade shafts and integral blade restrictors (pins)
- Blade restrictors prevent the blades from opening beyond a certain angle

Materials and surfaces

External weather louvre

- P1: Powder-coated, RAL CLASSIC colour
- PS: Powder-coated, DB colour

WG-AL-KUL

Variant

- External weather louvre made of aluminium, with non-return damper
- 1: Fresh air opening
- 2: Exhaust air opening

Nominal sizes

- B: 200 – 1600 mm, in increments of 1 mm
- H: 180, 345, 510, 675, 840, 1005, 1170, 1335, 1500, 1665 mm (intermediate sizes 183 – 1664 in increments of 1 mm)
- Any combination of B × H

Parts and characteristics

- Border
- Regular blades and bottom blade
- Wire mesh
- Optional insect screen
- Visible mullion or stabilising mullion at the rear, from B = 1385 mm
- Casing of non-return damper
- Blades with low-friction bearings
- Blade restrictors
- Blade tip seals
- Bottom travel stop (angle section)
- Visible mullion at the rear from B = 1000 mm

Construction features

External weather louvre

- Free area of approx. 60 %, with insect screen approx. 45 %
- Wire mesh at the rear, mesh aperture 20 × 20 × 1.8 mm
- Optional insect screen at the rear, mesh aperture 1.25 × 1.25 × 0.4 mm
- Border fixing holes

Non-return damper

- Casing, material thickness 1.25 mm
- Blades, material thickness 1 mm
- Flanges on both sides, suitable for duct connection, with corner holes
- Additional side bar with fixing holes to accommodate the blade shafts and integral blade restrictors (pins)
- Blade restrictors prevent the blades from opening beyond a certain angle

Materials and surfaces

External weather louvre

- P1: Powder-coated, RAL CLASSIC colour
- PS: Powder-coated, DB colour
- S2: Anodised to EURAS standard, E6-C-31 ...35
- S3: Anodised to EURAS standard, E6-C-0

Materials

Order code detail	Part	Material	Notes
-	Front border	Formed sheet steel, galvanised	Material thickness 1.5 mm
	Blades	Formed sheet steel, galvanised	Material thickness 0.63 mm
-	Mullion	Formed sheet steel, galvanised	From B = 1385 mm
	Wire mesh	Galvanised steel	
-	Casing and travel stop (angle section) of the non-return damper	Galvanised sheet steel	
	Blades	Formed aluminium	
-	Centre mullion	Galvanised sheet steel	From B = 1000 mm
	Blade shafts	Brass	
-	Side bar	PVC plastic	
	Blade tip seals	Foamed polyester	
-	Blade restrictors	Plastic	
AL	Front border	Extruded aluminium sections, material no. EN AW-6060 T66	Material thickness 1.7 mm
	Blades	Extruded aluminium sections, material no. EN AW-6060 T66	Material thickness 1.35 mm
AL	Stabilising mullion	Extruded aluminium sections, material no. EN AW-6060 T66	From B = 1385 mm
1	Insect screen	Galvanised steel	Only WG-AL-JZ
2	Wire mesh	Stainless steel, material no. 1.4301	Only WG-AL-JZ
3	Wire mesh	Stainless steel, material no. 1.4301	Only WG-AL-JZ
	Insect screen	Stainless steel, material no. 1.4301	Only WG-AL-JZ

Surfaces

Order code detail	Part	Surface	Notes
-	Border and blades	Untreated	
P1-RAL ...	Border and blades	Powder-coated, RAL ... CLASSIC	
PS-DB ...	Border and blades	Powder-coated, DB ...	
S2	Border and blades	Anodised to EURAS standard, E6-C-31...35	Only WG-AL-KUL
S3	Border and blades	Anodised to EURAS standard, E6-C-0	Only WG-AL-KUL

WG-KUL, weight

H	B [mm]							
	200	400	600	800	1000	1200	1400	1600
mm	kg							
180	9	10	14	18	22	26	30	34
345	12	14	18	22	26	30	34	38
510	15	18	22	27	31	36	41	46
675	17	22	27	33	38	44	49	54
840	18	24	29	35	40	46	52	58
1005	21	27	33	40	46	53	59	65
1170	23	31	38	45	52	59	66	72
1335	25	33	41	49	56	64	71	79
1500	27	35	43	51	59	67	75	83
1665	30	38	46	54	62	70	78	86

WG-AL-KUL, weight

H	B [mm]							
	200	400	600	800	1000	1200	1400	1600
mm	kg							
180	8	9	13	17	20	24	27	30
345	11	12	16	20	23	27	29	33
510	14	16	19	24	27	31	34	38
675	15	20	24	29	33	38	42	47
840	16	21	25	30	34	40	44	50
1005	18	24	28	35	40	47	51	56
1170	20	27	33	41	46	52	56	62
1335	21	29	37	45	50	56	61	68
1500	24	32	39	47	53	59	65	72
1665	27	36	42	50	56	63	68	75

WG-KUL-1, WG-AL-KUL-1

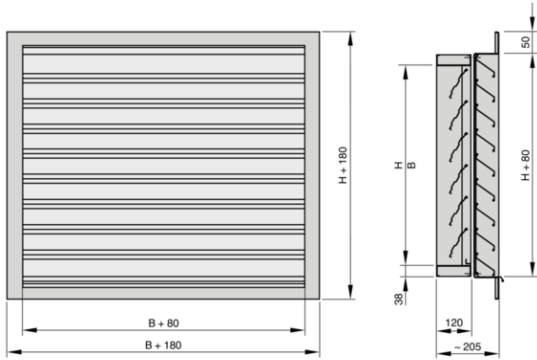

Illustration shows WG-KUL-1
WG-KUL-2, WG-AL-KUL-2

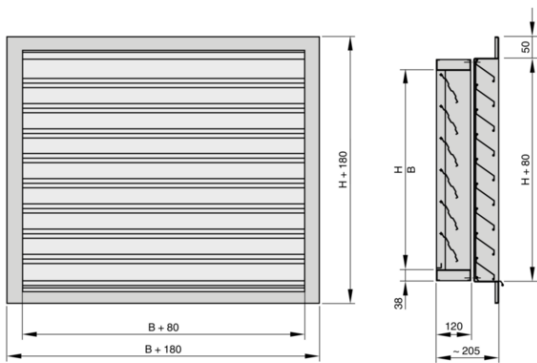

Illustration shows WG-KUL-2

Installation details, Basic information and nomenclature



Installation and commissioning

- With or without installation subframe
- Vertical installation
- Straight upstream section required (at least $B + H$) on the pressure side of fans
- Ensure a gradual start-up of fans to avoid a sudden pressure increase

Wall installation without installation subframe

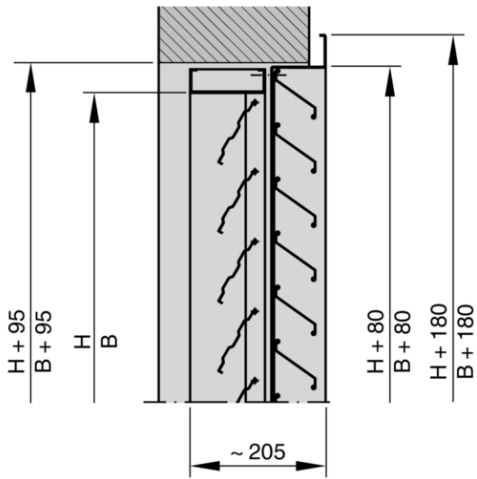
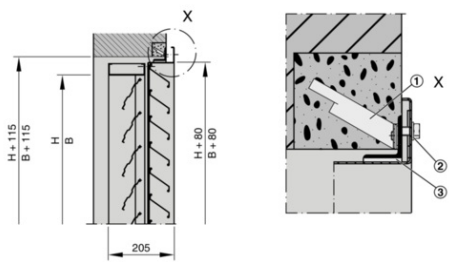

Illustration shows WG-KUL-1

Installation dimensions – WG-KUL-1, WG-KUL-2, WG-AL-KUL-1, WG-AL-KUL-2



- ① Fixing tab
- ② Hexagon head screw with washer
- ③ Installation subframe

Illustration shows WG-KUL-1/.../ER

Nomenclature

L_{WA} [dB(A)]

A-weighted sound power level of air-regenerated noise for the louvre

A [m²]

Upstream cross section

v [m/s]

Airflow velocity based on the upstream cross section

v_t [m/s]

Airflow velocity based on the upstream cross section (type NL)

V [m³/h] and [l/s]

Volume flow rate

Δp_t [Pa]

Total differential pressure

All sound power levels are based on 1 pW.

Principal dimensions

B [mm]

Duct width

B_1 [mm]

Duct width for subdivided louvres

H [mm]

Duct height

H_1 [mm]

Duct height for subdivided louvres

n []

Number of flange screw holes

m [kg]

Weight