



SCHOOLAIR-D



TESTED TO VDI 6022



WATER CONNECTION



SUPPLY AIR SLOT

SCHOOLAIR-D

SUPPLY AND EXTRACT AIR UNIT WITH HEAT EXCHANGER AND HEAT RECOVERY, SECONDARY AIR OPTION (BASED ON AIR QUALITY), FOR INSTALLATION BELOW THE CEILING SLAB

Ready-to-operate decentralised ventilation unit that provides good comfort levels, used for the ventilation and extract ventilation of rooms such as classrooms in schools

- Acoustically optimised EC fans with low specific fan powers, SFP-1 according to EN 13779
- Plate heat exchanger for heat recovery (air/air), including bypass damper with electric actuator (open-close)
- Heat exchanger for heating and cooling as 2-pipe or 4-pipe system
- Reduction of fine dust and pollen contamination due to integral filters; F7 fresh air filter
- The condensate drip tray is useful if the temperature temporarily falls below the dew point
- Motorised shut-off dampers, normally closed (NC)
- Installation without interruption to the operations of the respective school
- Easy filter change, no tools required

Optional equipment and accessories

- Modular control system FSL-CONTROL II, specially for decentralised ventilation systems
- Demand-based fresh air volume, free cooling and night purge, depending on control strategy
- Automatic switching to secondary air mode (based on air quality)
- Variable heat recovery
- Powder-coated RAL 9005 (black, casing) or RAL 9010 (white, cover)

Application

Application

- Ventilation and extract ventilation of rooms with a depth up to approx. 6 m
- 2-pipe or 4-pipe heat exchangers enable good comfort levels
- Supply air discharge from supply air slots
- Energy-efficient solution since water is used for heating and cooling
- For new buildings, refurbishment projects and revitalisation projects
- Installation below the ceiling slab and near an external wall
- Typical applications include classrooms in schools, playrooms in daycare facilities, smaller meeting rooms and offices with a high air change rate

Special characteristics

- Decentralised ventilation unit for high volume flow rates
- Air-water heat exchanger as 2-pipe or 4-pipe system, with G $\frac{1}{2}$ " union nuts and flat seals
- Cross flow heat exchanger for heat recovery, including bypass damper with electric actuator
- Motorised shut-off dampers for fresh air and exhaust air, normally closed (NC) in order to prevent uncontrolled airflows
- The condensate drip tray is useful if the temperature temporarily falls below the dew point
- Ceiling plate with height-adjustable frame (up to +29 mm) and integral supply and extract air slots
- 2 energy-efficient and acoustically optimised EC fans with low specific fan powers, SFP-1 according to EN 13779
- Meets the hygiene requirements of VDI 6022



- Recuperative heat recovery with motorised variable bypass all year round
- Compact construction, hence particularly suitable for refurbishment projects
- Demand-based ventilation and extract ventilation is possible by means of monitoring the room air quality and with dedicated control equipment
- Automatic switching to secondary air mode (only with an air quality sensor) if the room air quality (measured with the integral VOC sensor, for example) is between the previously defined range. The unit always starts in secondary air mode, which is more energy efficient.

Nominal sizes

- 1640 × 400 × 800 mm (B × H × T)

Description

Variants

- SCHOOLAIR-D – volume flow rates: 150, 200, 250 and 300 m³/h, with cross flow plate heat exchanger for heat recovery

Construction

- Powder-coated RAL 9005, black

Useful additions

- Modular control system FSL-CONTROL II, specially for decentralised ventilation systems
- Connecting hoses

Construction features

- 2 energy-efficient EC fans with low specific fan powers, SFP = 1 according to EN 13779
- The supply air is discharged to the room as an inducing displacement flow from the supply air slots
- The extract air is removed through slots

Materials and surfaces

- Casing, ceiling plate, filter chamber cover, fans and hanging brackets are made of galvanised sheet steel
- Heat exchanger with copper tubes and aluminium fins
- Plate heat exchanger (heat recovery) made of aluminium
- Casing powder-coated, black (RAL 9005)
- F7 filter medium made of moisture-resistant glass fibre paper (certified by Eurovent)
- Mineral wool lining to DIN 4102, fire rating class A, faced with glass fibre fabric as a protection against erosion, effective with airflow velocities up to 20 m/s
- Closed cell sealing strips
- Ceiling plate powder-coated pure white (RAL 9010)
- Supply and extract air slots made of aluminium, air control blades made of polystyrene

Standards and guidelines

- Façade ventilation units of Type SCHOOLAIR-D conform to VDI 6035 and VDMA 24390
- Hygiene certificate to VDI 6022
- Heating/cooling fluid conforms to VDI 2035
- Meets the requirements of EU directive 1253/2014 (ErP)

Maintenance

- VDI 6022, Part 1, applies (Hygiene requirements for ventilation and air-conditioning systems and units)
- The heat exchanger can be vacuumed with an industrial vacuum cleaner if necessary
- It can also be cleaned with commercial, non-aggressive cleaning agents

TECHNICAL INFORMATION

Function, TECHNICAL DATA, QUICK SIZING, SPECIFICATION TEXT, ORDER CODE, Related products

Functional description

Decentralised supply and extract air units for room ventilation and for dissipating cooling loads and heat loads.

An EC centrifugal fan takes in the fresh air which then flows through the motorised shut-off damper and the F7 filter.

Once the fresh air has passed the fan, it flows through the recuperative heat exchanger for heat recovery; it is possible to bypass the recuperative heat exchanger in order to protect it, or when it is sensible with regard to energy efficiency.

If necessary, the air is heated or cooled by the heat exchanger before it is discharged to the room from the supply air slot

The extract air is removed through an extract air slot, passes a filter, then flows through the heat exchanger (heat recovery), the extract air fan and the motorised shut-off damper before it is discharged to the outside as exhaust air.

If the room air quality is good, the unit can be operated in secondary mode only.

Schematic illustration of SCHOOLAIR-D

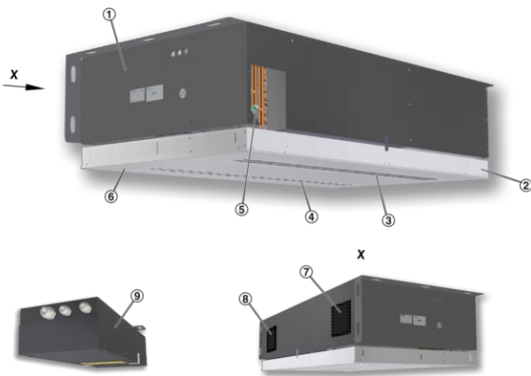

- ① Casing with mounting bracket
- ② Height-adjustable frame
- ③ Supply air slot (SRS)
- ④ Extract air slot (SET)
- ⑤ Water connections
- ⑥ Ceiling plate
- ⑦ Fresh air opening (SRO)
- ⑧ Exhaust air opening (SEH)
- ⑨ Control equipment box (optional)

Ventilation diagram for SCHOOLAIR-D (optional control equipment)

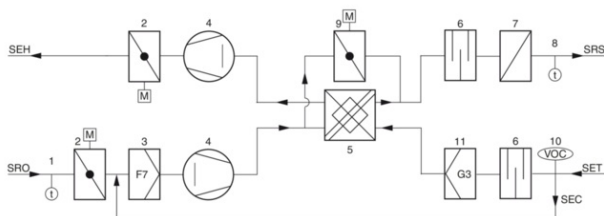

- SEH Single room exhaust air
- SRO Single room fresh air
- SRS Single room supply air
- SET Single room extract air
- SEC Secondary air cellular office

- 1 Fresh air temperature sensor (optional)
- 2 Shut-off damper

- 3 Fine dust filter F7
- 4 EC fan
- 5 Heat recovery
- 6 Sound attenuator
- 7 Heat exchanger
- 8 Supply air temperature sensor (optional)
- 9 Bypass damper
- 10 Air quality sensor (optional)
- 11 G3 extract air filter

| | |
|----------------------------------------|-----------------------------|
| Width | 1640 mm |
| Height | 400 mm |
| Depth | 800 mm |
| Fresh air flow rate | Up to 300 m ³ /h |
| Supply air flow rate | Up to 300 m ³ /h |
| Cooling capacity | Up to 1500 W |
| Heating capacity | Up to 5990 W |
| Room cooling capacity | Up to 792 W |
| Room heating capacity | Up to 1984 W |
| Max. operating pressure, water side | 6 bar |
| Max. operating temperature, water side | 75 °C |
| Sound power level | 32 – 47 dB(A) |
| Supply voltage | 230 V AC ±10 %, 50/60 Hz |
| Weight | Approx. 100 kg |

SCHOOLAIR-D (sizing examples)

| | | | | | |
|---------------------------------------------------|-------------------|-------|-------|-------|-------|
| Supply air flow rate | m ³ /h | 150 | 200 | 250 | 300 |
| Fresh air flow rate | m ³ /h | 150 | 200 | 250 | 300 |
| Total cooling capacity | W | 685 | 911 | 1150 | 1350 |
| Room cooling capacity | W | 401 | 534 | 676 | 792 |
| Temperature of the air in the unit | °C | 32.0 | 32.0 | 32.0 | 32.0 |
| Rel. humidity | % | 40.0 | 40.0 | 40.0 | 40.0 |
| Water content of the dry air | g/kg | 11.9 | 11.9 | 11.9 | 11.9 |
| Supply air temperature | °C | 18 | 18 | 17.9 | 18.1 |
| Condensation | g/h | 0 | 0 | 0 | 0 |
| Chilled water flow rate | l/h | 70 | 110 | 170 | 210 |
| Water temperature, inlet | °C | 16 | 16 | 16 | 16 |
| Water temperature, outlet | °C | 24.4 | 23.1 | 21.8 | 21.5 |
| Pressure drop – water side | kPa | <3 | <3 | <7 | <9 |
| Total heating capacity | W | 3120 | 4120 | 5180 | 5990 |
| Room heating capacity | W | 1102 | 1443 | 1820 | 1984 |
| Temperature of the air in the unit | °C | -12.0 | -12.0 | -12.0 | -12.0 |
| Supply air temperature | °C | 43 | 42.6 | 42.8 | 40.8 |
| Hot water flow rate | l/h | 60 | 90 | 130 | 150 |
| Water temperature, inlet | °C | 60 | 60 | 60 | 60 |
| Water temperature, outlet | °C | 15.2 | 20.4 | 25.6 | 25.5 |
| Pressure drop – water side | kPa | 0.8 | 1.5 | 2.9 | 3.7 |
| Sound power level L _{WA} | dB(A) | 32 | 38 | 43 | 47 |
| Sound pressure level with 8 dB system attenuation | dB(A) | 24 | 30 | 35 | 39 |

Type SCHOOLAIR-D ventilation unit for ceiling installation, supply and extract air function, secondary air option (based on air quality), heat recovery and heating function, for installation below the ceiling slab near an external wall.

Special characteristics

- Decentralised ventilation unit for high volume flow rates
- Air-water heat exchanger as 2-pipe or 4-pipe system, with G½" union nuts and flat seals
- Cross flow heat exchanger for heat recovery, including bypass damper with electric actuator
- Motorised shut-off dampers for fresh air and exhaust air, normally closed (NC) in order to prevent uncontrolled airflows
- The condensate drip tray is useful if the temperature temporarily falls below the dew point
- Ceiling plate with height-adjustable frame (up to +29 mm) and integral supply and extract air slots
- 2 energy-efficient and acoustically optimised EC fans with low specific fan powers, SFP-1 according to EN 13779
- Meets the hygiene requirements of VDI 6022
- Recuperative heat recovery with motorised variable bypass all year round
- Compact construction, hence particularly suitable for refurbishment projects
- Demand-based ventilation and extract ventilation is possible by means of monitoring the room air quality and with dedicated control equipment

- Automatic switching to secondary air mode (only with an air quality sensor) if the room air quality (measured with the integral VOC sensor, for example) is between the previously defined range. The unit always starts in secondary air mode, which is more energy efficient.

Materials and surfaces

- Casing, ceiling plate, filter chamber cover, fans and hanging brackets are made of galvanised sheet steel
- Heat exchanger with copper tubes and aluminium fins
- Plate heat exchanger (heat recovery) made of aluminium
- Casing powder-coated, black (RAL 9005)
- F7 filter medium made of moisture-resistant glass fibre paper (certified by Eurovent)
- Mineral wool lining to DIN 4102, fire rating class A, faced with glass fibre fabric as a protection against erosion, effective with airflow velocities up to 20 m/s
- Closed cell sealing strips
- Ceiling plate powder-coated pure white (RAL 9010)
- Supply and extract air slots made of aluminium, air control blades made of polystyrene

Construction

- Powder-coated RAL 9005, black

Technical data

- Width: 1640 mm
- Height: 400 mm
- Depth: 800 mm
- Fresh air flow rate: up to 300 m³/h
- Supply air flow rate: up to 300 m³/h
- Cooling capacity: up to 1500 W
- Heating capacity: up to 5990 W
- Room cooling capacity: up to 792 W
- Room heating capacity: up to 1984 W
- Maximum operating pressure: 6 bar
- Max. operating temperature: 75 °C
- Sound power level: 32 – 47 dB(A)
- Supply voltage: 230 V AC ± 10 %, 50/60 Hz
- Weight: approx. 100 kg
- Rating: 120 VA (unit only)
- Power consumption: 59 W with medium speed (nominal volume flow rate)

Sizing data

Fresh air

- V _____ [m³/h]

Supply air

- V _____ [m³/h]

Room cooling capacity

- Q _____ [W]

Room heating capacity

- Q _____ [W]

- L_{WA} _____ [dB(A)]

Decentralised ventilation units are technically advanced products of high quality; they offer a wide range of configuration options. For specification details regarding your project please contact your nearest TROX branch or subsidiary.

SCHOOLAIR - D - 4 / 1690 x 400 x 800 / R / MA - T / B / V / Z / A / HV - R - 0,4 / KV - R - 0,4

| | |
|---------------------------------------------------------------------------------------------------------------------------|------------------------------------------------------------------------------------------------|
| <p>1 Type</p> <p>SCHOOLAIR-D Ceiling units</p> | <p>9 Supply air temperature sensor</p> <p>Z With</p> |
| <p>2 Heat exchanger</p> <p>2 2-pipe 4 4-pipe</p> | <p>10 Fresh air temperature sensor</p> <p>No entry: none master only A With</p> |
| <p>3 Dimensions [mm]</p> <p>B x H x T 1690 x 400 x 800</p> | <p>11 Heating valve</p> <p>HV With</p> |
| <p>4 Control equipment</p> <p>No entry: none R With</p> | <p>12 Lockshield – heating circuit</p> <p>R With</p> |
| <p>5 Control function</p> <p>MA Master (room module and control module) SL Slave (control module)</p> | <p>13 kVS value – heating valve</p> <p>0,25 0,40 0,63 1,00 F0,50</p> |
| <p>6 Real time clock</p> <p>No entry: none master only T With</p> | <p>14 Cooling valve</p> <p>For 4-pipe systems only KV with</p> |
| <p>7 Interface</p> <p>No entry: none master only B BACnet MS/TP or Modbus RTU L LonWorks LON-FTT10</p> | <p>15 Lockshield – cooling circuit</p> <p>R With</p> |
| <p>8 Air quality sensor</p> <p>No entry: none master only V VOC sensor</p> | <p>16 kVS value – cooling valve</p> <p>0,25 0,40 0,63 1,00 F0,50</p> |

Dimensions and weight



SCHOOLAIR-D

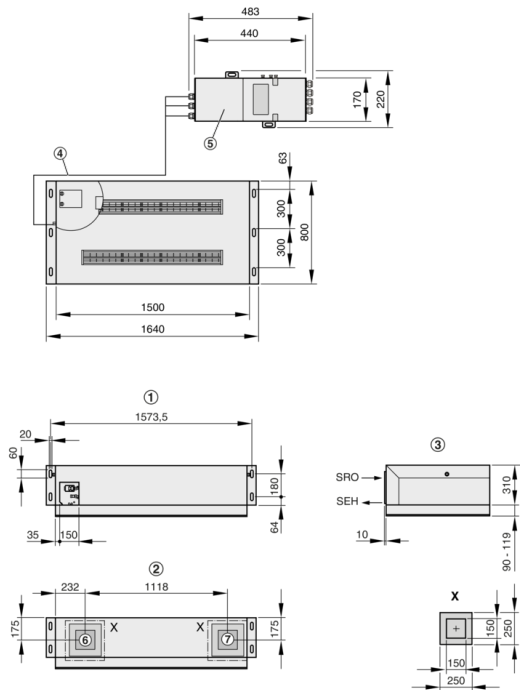

- ① As seen from the room
- ② View from outside (façade)
- ③ Side view
- ④ 5 m cable
- ⑤ Control equipment box (95 mm high)
- ⑥ Exhaust air opening (SEH)
- ⑦ Fresh air opening (SRO)



Installation example



Installation and commissioning

- Installation below the ceiling slab and near an external wall
- The ventilation unit is fitted with two hanging brackets to screw-fix it to the façade system or an external wall
- Weather protection for the fresh air and exhaust air openings to be provided by others
- The fresh air connection is provided by two ventilation openings in the façade system or external wall (to be provided by others), preferably sloping towards the outside
- Free area of ventilation openings: 0.04 – 0.05 m² for each opening
- Installation and connections to be performed by others; fixing, connection and sealing material to be provided by others
- The water flow and return connections are on the left-hand side of the unit when seen from the room
- Vents and drainage by others
- The electrical connection is on the left-hand side of the unit when seen from the room
- The under sill trim must not obstruct installation or deinstallation of the unit or maintenance access on the front of the unit

L_N [mm]

Nominal length

L_{WA} [dB(A)]

Sound power level

t_{Pr} [°C]

Primary air temperature

t_{wv} [C°]

Water flow temperature – cooling/heating

t_R [C°]

Room temperature

t_R [C°]

Room temperature

t_{AN} [C°]

Secondary air intake temperature

Q_{Pr} [W]

Thermal output – primary air

Q_{tot} [W]

Thermal output – total

Q_w [W]

Thermal output – water side, cooling/heating

V_{Pr} [l/s]

Primary air volume flow rate

V_{Pr} [m³/h]

Primary air volume flow rate

V_w [l/h]

Water flow rate – cooling/heating

V [l/h]

Volume flow rate

Δt_w [K]

Temperature difference – water

Δp_w [kPa]

Pressure drop, water side

Δp_t [Pa]

Total pressure drop, air side

Δt_{Pr} = t_{Pr} - t_R [K]

Difference between primary air temperature and room temperature

Δt_{RwV} = t_{wV} - t_R [K]

Difference between water flow temperature and room temperature

Δt_{wm-Ref} [K]

Difference between mean water temperature and reference temperature

L_N [mm]

Nominal length

Inducing displacement flow

The supply air is discharged near the external wall and with a medium velocity between 1.0 and 1.5 m/s. Due to the induction effect the supply air velocity is rapidly reduced such that, in cooling mode, the supply air displaces the room air over the entire floor area. The convection from people and other heat sources causes the fresh air from the pool to rise and create comfortable conditions in the occupied zone.

Heat exchanger

The maximum water-side operating pressure for all heat exchangers is 6 bar.

The maximum water flow temperature (heating circuit) for all heat exchangers is 75 °C; if flexible hoses are used, the water flow temperature should not exceed 55 °C. Units for other pressures and temperatures are available on request.

The water flow temperature (cooling circuit) should be at least 16 °C such that it does not permanently fall below the dew point. For units with a condensate drip tray the water flow temperature may be reduced to 15 °C.

Heat exchanger as 2-pipe system

Air-water systems with a 2-pipe heat exchanger may be used for either heating or cooling. In changeover mode it is possible to use all units within a water circuit exclusively for cooling in summer and exclusively for heating in winter.

Heat exchanger as 4-pipe system

Air-water systems with a 4-pipe heat exchanger may be used for both heating and cooling. Depending on the season, i.e. especially in spring and autumn, it may be possible that an office has to be heated in the morning and cooled in the afternoon.

Schematic illustration of inducing displacement flow ventilation

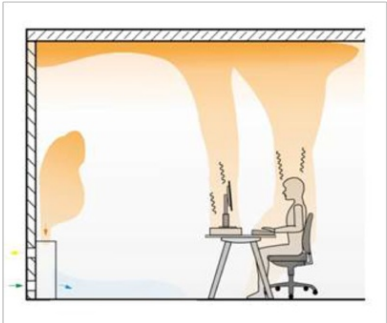

Heat exchanger as 2-pipe system

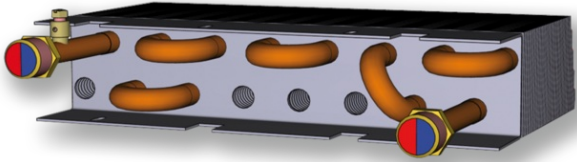

Heat exchanger as 4-pipe system

